

# LDF120-0CW-14

## Super Cool White

3mm, Cylindrical, 3.7mm Height  
120° viewing angle, (cylindrical body)

DWG BY:  
LL / JAG  
07-27-06

CHK BY:  
PL  
07-28-06

QA:  
\_\_\_\_  
\_\_-\_\_-\_\_

MFG:  
\_\_\_\_  
\_\_-\_\_-\_\_

REVISION LTR -  
07-27-06

## Features:

- High intensity
- Standard 3mm diameter no flange package
- Tinned leads
- Pb-free

## Package Dimensions:

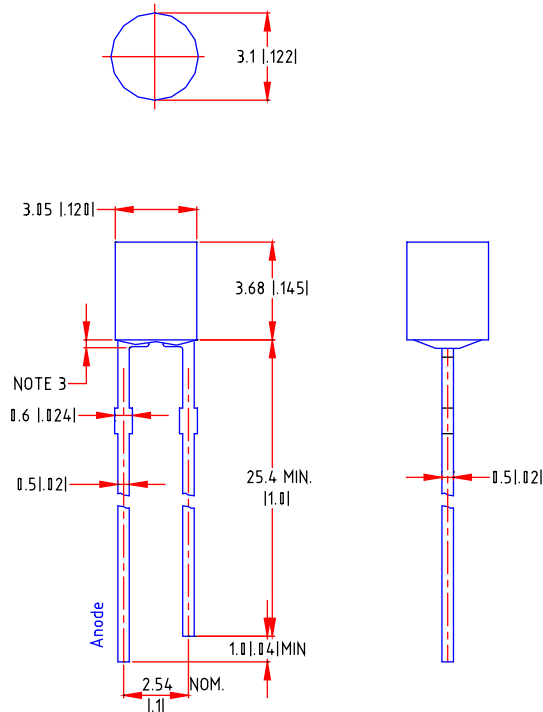

Part No.	Chip Material	Lens Color	Emission Color
LDF120-0CW-14	InGaN	Water Clear	Super Cool White

### Notes:

1. All dimensions are in millimeters (inches).
2. Tolerance is  $\pm 0.25\text{mm}$  (.010") unless otherwise noted.
3. Protruded resin under flange is 1.0mm (.04") max.
4. Lead spacing is measured where the leads emerge from the package.
5. Specifications are subject to change without notice.
6. Precautions for ESD: Static electricity and surge can damage the LED. It is recommended to use a wristband or anti-electrostatic glove when handling the LED. All devices, equipment and machinery must be properly grounded.

### Absolute Maximum Ratings at Ta=25°C

Parameter	MAX.	Unit
Power Dissipation	80	mW
Peak Forward Current (1/10 Duty Cycle, 0.1ms Pulse Width)	100	mA
Continuous Forward Current	20	mA
Derating Linear From 50°C	0.4	mA/°C
Reverse Voltage	5	V
Electrostatic Discharge (ESD)	150	V
Operating Temperature Range	-20°C to +80°C	
Storage Temperature Range	-30°C to +100°C	
Lead Soldering Temperature [4mm(.157") From Body]	260°C for 5 Seconds	

### Electrical Optical Characteristics at Ta=25°C

Parameter	Symbol	Min.	Typ.	Max.	Unit	Test Condition
Luminous Intensity	I <sub>v</sub>	690	900	---	mcd	I <sub>F</sub> =20mA (Note 1)
Viewing Angle	2θ <sub>1/2</sub>	110	120	130	Deg	(Note 2)
Forward Voltage	V <sub>F</sub>	---	3.2	4.0	V	I <sub>F</sub> =20mA
Reverse Current	I <sub>R</sub>	---	---	50	μA	V <sub>R</sub> =5V
SCP	---	---	0.29	---	cd	I <sub>F</sub> =20mA
Lumens	---	---	3.60	---	lm	I <sub>F</sub> =20mA
Radiant Intensity	---	---	3000	---	μW/sr	I <sub>F</sub> =20mA
Color Rendering Index	CRI	79	---	83	---	---

Color Rank	x	y	x	y	x	y	x	y
LTC & LTD	0.270	0.285	0.288	0.250	0.305	0.275	0.295	0.325

Notes:

- Luminous intensity is measured with a light sensor and filter combination that approximates the CIE eye-response curve.
- θ<sub>1/2</sub> is the off-axis angle at which the luminous intensity is half the axial luminous intensity.
- Forward voltage measurement allowance is ±0.1V
- Luminous Intensity Measurement Allowance is ± 10%.

**Typical Electrical / Optical Characteristics Curves**  
 (25°C Ambient Temperature Unless Otherwise Noted)

